

# AN EXPERIMENTAL INVESTIGATION OF ELECTRODE EFFECTS

Yu. V. Baryshev, V. O. German, B. V. Parfenov,  
and B. S. Solov'ev

We investigate the potential change at the cathode in relation to the current flowing through the gas with different amounts of additive in the flow in a particular range of temperature of the electrode working surface and with electrodes of various materials. We consider a simplified model and take into account the possibility of extending the obtained results to a real apparatus. The simplification is achieved by excluding the magnetic field from consideration and investigating the case of an electric field applied to the electrodes.

**Apparatus.** The source of the low-temperature air plasma was a 300-kW dc plasmatron with gas stabilization of the arc [1]. The gas parameters at the entrance to the working channel were: mean mass temperature  $\sim 2400\text{--}2600^\circ\text{K}$ , velocity  $\sim 350\text{--}450\text{ m/sec}$ , and flow rate  $\sim 30\text{--}35\text{ g/sec}$ .

The gas emerging from the plasmatron nozzle passed through a device for introduction of the additive (potassium concentration  $\psi=0\text{--}1.2\%$ ) and a fore chamber. The fore chamber ensured better mixing of the additive with the flow and shaped the flow for entry into the uncooled ceramic channel 4 (Fig. 1), 180 mm long and  $50 \times 18\text{ mm}^2$  in cross section, constructed of separate rectangular units. The electrodes were mounted in the side walls of the channel.

The temperature  $T_w$  of the working surface of the electrode was continuously measured by a TFPG-1 pyrometer and recorded on a ÉPP-09 potentiometer. The spectral characteristics of the photodiode ( $\lambda_{\text{eff}}=1.5\ \mu$ ) of the pyrometer 6 were chosen to minimize the effect of emission of the potassium.

The OSMU-2 magnetic system provided a magnetic field of up to 1.6 T in an 80-mm gap. The pole pieces were  $800 \times 100\text{ mm}$ .

**Measuring Circuit.** To investigate the effect of the frequency of the supply voltage on the current-voltage characteristics we used three power supplies: a dc supply 15, a 50-Hz ac supply 13, and a 200-Hz ac supply 14. During the experiment we used the three supplies in turn. The direct voltage could be varied smoothly from  $-110\text{ V}$  to  $110\text{ V}$ . The amplitude of the alternating voltage was 150 V.

The current circuit contains five resistors 24, which act as ballast resistors and are also used for measurement of the current. The voltage drop on these resistors is proportional to the current and, hence, the deflection of the beams of oscillographs 11 and 12 is also proportional to the current. Some of the resistors are shunted by a switch and this alters the current scale.

Depending on the position of the switch 16 the voltage applied to the oscillographs is that between electrodes 1 and 2 or between electrode 1 and probe 3.

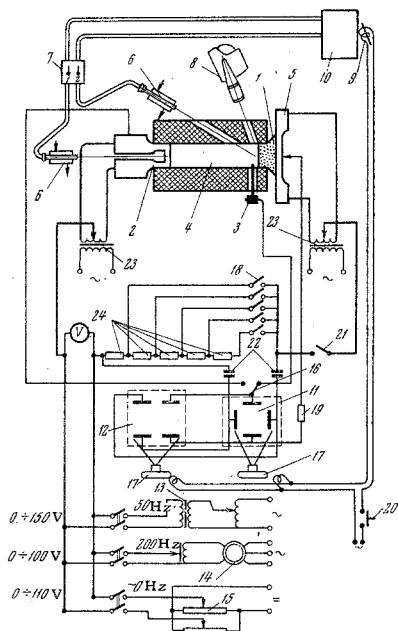

Fig. 1

Moscow. Translated from Zhurnal Prikladnoi Mekhaniki i Tekhnicheskoi Fiziki, Vol. 9, No. 4, pp. 119-123, July-August, 1968. Original article submitted February 29, 1968.

© 1972 Consultants Bureau, a division of Plenum Publishing Corporation, 227 West 17th Street, New York, N. Y. 10011. All rights reserved. This article cannot be reproduced for any purpose whatsoever without permission of the publisher. A copy of this article is available from the publisher for \$15.00.

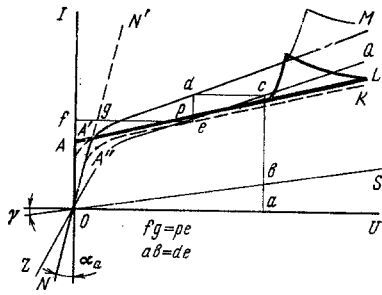

Fig. 2

The oscillograph 12 is of the double-beam type. The first beam gives the current sweep on the screen and the second gives the voltage sweep. Oscillograph 11 is of the single-beam type. The vertical deflection on its screen is proportional to the voltage and the horizontal deflection is proportional to the current. Thus, the curve described by the beam is the current-voltage characteristic. The screens of both oscillographs are photographed. The start of the oscillographs is synchronized. The current-voltage characteristics are recorded as the electrode temperature increases. The time of photography of each frame is automatically marked on the tape of the instrument 10, which records the temperature. During one experiment (~ 6 min) up to 30 frames, corresponding to different electrode surface temperatures, are taken.

**Current-Voltage Characteristics.** The measuring circuit enabled us to record three kinds of current-voltage characteristics [1]: the electrode-probe, the electrode-electrode, and the stop characteristic. By altering the range of current and voltage measurement we could alter the scale of the oscillograms. A change in the applied voltage affects the range of the characteristics without affecting the characteristic angles of inclination.

A typical electrode-probe current-voltage characteristic for electrodes of silicified graphite has the form illustrated in Fig. 2. The branch of this characteristic with  $j > 0$  ( $j = I/S$ , where  $I$  is the current in the electrode circuit, and  $S$  is the electrode area) corresponds to operation of the electrode as a cathode (cathode branch), and that with  $j < 0$  is the anode branch.

According to [1], a characteristic of the anode branch of the oscillogram is  $\tan \alpha = \Delta U_a / I \approx R_a$ , where  $R_a$  is the resistance of the gas layer between the electrode and the probe.

The cathode branch of the oscillogram has three characteristic portions [1]: the portion OA is characterized by a level of currents  $j^*$  corresponding to the point A; the portion AB is characterized by  $\cotan \alpha_c = \tan \beta$ ; the portion BB'C is characterized by a cathode fall  $U$  below which there is no arc regime of the cathode. An investigation [2] of a discharge in conditions corresponding to this part of the characteristic showed that in this region the discharge is arc-like with distinct spots.

Figure 3 shows the general form of the electrode-electrode current-voltage characteristic for the same materials. Since the processes close to the cathode play a decisive role in the channel the two branches of the electrode-electrode characteristic are qualitatively similar in structure to the cathode branches of the electrode-probe characteristic.

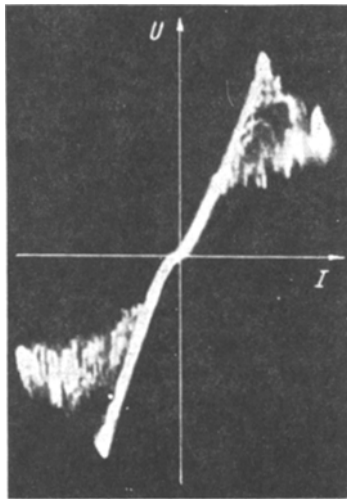

Fig. 3

If the electrode-electrode characteristic is recorded in the presence of a magnetic field a correction must be made for the induced emf.

**Measurement of Resistances.** The resistances of the inter-electrode gap and the insulating walls connected in parallel (Fig. 4, where 1 is the cathode, 2 is the cathode fall region, 3 is the boundary layer at the cathode, 4 is the core of the flow, 5 is the boundary layer at the anode, 6 is the anode fall, 7 is the anode, and 8 is the probe) can be separately determined by an analysis of the characteristics.

The availability of electrode-probe and electrode-electrode current-voltage characteristics recorded successively at sufficiently short intervals enabled us to determine the total resistance of the gap.

A diagram of the currents flowing between the electrodes in the working plasmatron is shown in Fig. 4. To estimate the current flowing through the insulating walls we recorded the "stop" current-voltage characteristic at the instant when the plasmatron was stopped with a voltage imposed on the working electrodes. The angle of in-

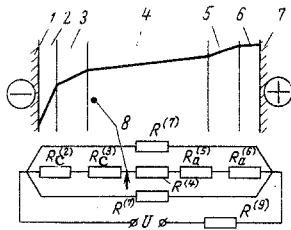

Fig. 4

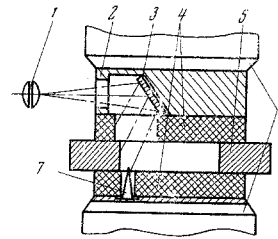

Fig. 5

clination of this characteristic to the current axis characterizes the resistance of the insulation between the electrodes.

**Treatment of Characteristics.** Figure 2 illustrates the replotting of the current-voltage characteristic. The potential drops on the electron-probe region in the case where the investigated electrode operates as a cathode or anode are determined by the resistances

$$R_{c,a} = \Delta U / I', \quad R_c = R_c^{(2)} + R_c^{(3)}, \quad R_a = R_a^{(2)} + R_a^{(3)}$$

Here  $\Delta U$  is the potential drop in the region between the investigated electrode and the probe,  $I'$  is the current in the electrode circuit minus the current flowing through the insulation,  $R^{(2)}$  is the ratio of the anode or cathode potential drop to the current and  $R^{(3)}$  is the resistance of the gas layer between the electrode and probe. The subscripts c and a denote that the investigated electrode operates as a cathode or anode.

If we assume that  $R_c^{(3)} = R_a^{(3)}$  and on the basis of [2] take  $R_a^{(2)}$  as negligibly small at the current densities measured in the experiments, then we can say that  $R_a = R_a^{(3)} = R_c^{(3)}$ .

Thus, by subtracting the potential drop on the resistance  $R_a$  from the line NOA"K (Fig. 2) for given values of  $I$  we obtain the line OAL, which is the characteristic of the relationship between the cathode fall and the current density.

**Registration of Arc Spots.** The cine photographs were taken with a Pentazet-35 camera at a rate of  $2000 \text{ sec}^{-1}$ . The filming rate was measured and the lifetime of the spots was determined from time marks made at a rate of  $1000 \text{ sec}^{-1}$ .

For the photography we selected 15-TT-800 film, which in comparison with KH films has a lower initial density ( $D_0 = 0.24$ ), a higher contrast factor ( $\gamma = 1.6$ ) when processed in the same way, and a higher maximum density ( $D_{\text{max}} = 3.0-3.2$ ). The exposure had to be chosen so that the optical density of spots on the negative always lay on the threshold  $D_{\text{max}}$ . This enabled us to distinguish incandescent particles, which appeared occasionally on the electrode surface, from the arc spots.

Arcs on the cathode surface were registered in the absence of a magnetic field [2] and in experiments with an applied magnetic field. In the latter case a mirror with an external reflecting layer was mounted within the magnet pole piece to allow inspection of the electrode surface (Fig. 5). The use of the mirror enabled us to direct the axis of photography along the electrode surface and, thus, to investigate the structure of the arc discharge.

In the choice of scale of the photographs we took the following into account: With increase in scale the depth of definition is greatly reduced and with reduction of the diameter of the focal aperture of the lens the resolving power of the optical system is reduced. Hence, stopping-down of the lens to 8-11 should be regarded as the limit.

The scale was provisionally chosen so that the spot on the negative would be two to three orders greater than the natural grain of the negative. In this case the scale had to be in the range 1:4 to 1:1.

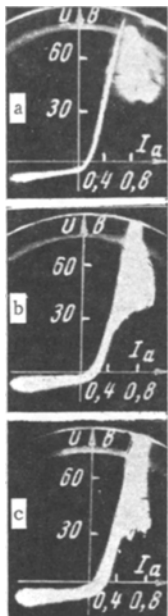

Fig. 6

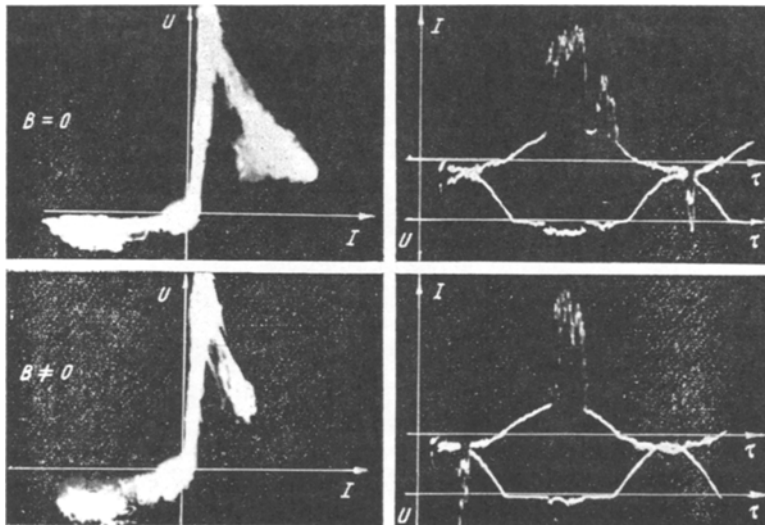

Fig. 7

A mirror mounted at an angle of 47-48° to the horizontal optic axis enabled us to observe the electrode surface at an angle of 2-3°. The zone of sharp focus was chosen in the middle of the electrode and when the scale of the photographs was ~1:2 was ~5 mm.

The scale of the photographs was finally decided from the following formula:

$$G = 0.066 nM (M + 1)$$

Here  $G$  is the depth of definition,  $n$  is the relative aperture of the lens,  $M$  is the reciprocal of the scale (the ratio of the linear dimensions of the picture plane to the linear dimensions of the frame).

**Experimental Results.** Typical current-voltage characteristics are shown in Figs. 3, 6, and 7. For comparison we show characteristics recorded for the same electrode surface temperatures and with the same concentrations of additive. Figure 6 shows that the frequency of the applied voltage had no effect on the form of the characteristic. Hence, the processes occurring near the electrode become steady in a time much smaller than the length of one cycle. This applies to the distributed discharge. In the case of the arc discharge the steady state does not set in. The current and voltage pulsations are presumably due to the dynamics of interaction of the arc column and the gas flow.

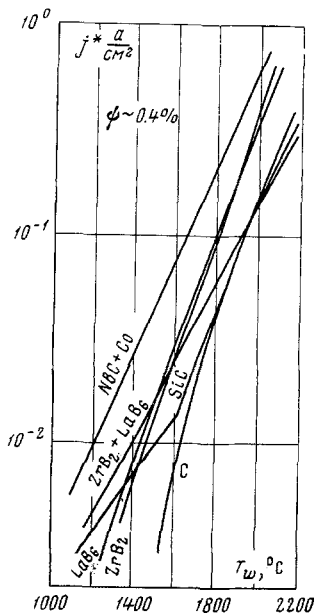

Fig. 8

Figure 7 compares the characteristics for different values of the magnetic field. Within the limits of experimental accuracy we could detect no effect of the magnetic field (1.3-1.5 T) on the form of the characteristics. The cine photographs indicated that the outward appearance of the arc discharge was unaltered when the magnetic field was switched on.

In view of this we can conclude that for investigation of the operation of electrodes we can use a simplified method in which a 50-Hz voltage is applied to the electrodes in the absence of a magnetic field. This facilitates investigation of different materials in a wide range of temperatures and concentrations of additive.

Some results of investigations carried out by the simplified method are shown in Fig. 8, where the parameter  $j^*$  is shown as a function of  $T_w$  and  $\psi$  for different materials. Empirical formulas representing this relationship have the form:

$$j^* = a \exp \{b/T_w\}$$

We give the values of the constants  $a$  ( $a/\text{cm}^2$ ) and  $b$  ( $\text{deg}^{-1}$ ) for some materials. The figures in the brackets give the amount of potassium (in %) added to the air flow:

$NbC + C_0$	$\left\{ \begin{array}{l} (0.4 \text{ k}) \\ (1.2 \text{ k}) \end{array} \right.$	$a = 2.2 \cdot 10^{-5}$	$b = 5.06 \cdot 10^{-3}$
		$a = 1.6 \cdot 10^{-4}$	$b = 4.25 \cdot 10^{-3}$
$ZrB_2$	$\left\{ \begin{array}{l} (0.4 \text{ k}) \\ (1.2 \text{ k}) \end{array} \right.$	$a = 1.5 \cdot 10^{-6}$	$b = 6.14 \cdot 10^{-3}$
		$a = 6.6 \cdot 10^{-7}$	$b = 7.06 \cdot 10^{-3}$
$ZrB_2 + LaB_6$	$\left\{ \begin{array}{l} (0.4 \text{ k}) \\ (1.2 \text{ k}) \end{array} \right.$	$a = 2.8 \cdot 10^{-8}$	$b = 4.26 \cdot 10^{-3}$
		$a = 1.1 \cdot 10^{-4}$	$b = 3.84 \cdot 10^{-3}$
$W + LaB_6$	$\left\{ \begin{array}{l} (0.4 \text{ k}) \\ (1.2 \text{ k}) \end{array} \right.$	$a = 7.4 \cdot 10^{-5}$	$b = 4.06 \cdot 10^{-3}$
		$a = 1.6 \cdot 10^{-5}$	$b = 5.57 \cdot 10^{-3}$

As distinct from these materials the formula for lanthanum hexaboride has the form

$$j^* = 0.014 + 1.12 \cdot 10^{-44} T_w^{13.96} a / \text{cm}^2$$

#### LITERATURE CITED

1. V. O. German and M. G. Morozov, "A dc plasmatron and some results of investigation of its operation," *Teplofizika vysokikh temperatur*, No. 5, 1965.
2. V. German, G. A. Lyubimov, and B. V. Parfenov, "An experimental investigation of the operation of an electrode in an air flow with potassium added," *Teplofizika vysokikh temperatur*, No. 3, 1967.